

# 1550nm CATV Erbium Doped Fiber Amplifier • DT Series

## Technical Specification

# CONTENT

<b>1.0 PRODUCT DESCRIPTION</b> .....	<b>1</b>
<b>2.0 PRODUCT FEATURE</b> .....	<b>2</b>
<b>3.0 MAIN APPLICATION</b> .....	<b>2</b>
<b>4.0 TECHNIQUE INDEX</b> .....	<b>3</b>
<b>5.0 OPTIC/ELECTRICAL SCHEMA</b> .....	<b>4</b>
5.1 DT-1X □□□ (CONVENTIONAL).....	4
5.2 DT-2X □□□ (BUILT-IN OPTICAL SWITCH).....	4
<b>6.0 PRODUCT SERIES</b> .....	<b>5</b>

## 1.0 PRODUCT DESCRIPTION

DT (2RU) series is a low noise, high performance, FTTP high power, multi-ports optical amplifier with gain spectrum band within 1540~1563nm. Each output port for optical amplifier has built-in well-performed CWDM. Every external up-link optical port of optical amplifier can connect with OLT PON port very conveniently. Each 1550nm (CATV)'s output optical port multiplex 1310/1490nm's data stream, in order to reduce the quantity of the component and improve the index and reliability of the system.

DT optical amplifier can be compatible with any FTTx PON Technology. It offers a flexible and low-cost solution for three-network integration and Fiber to the Home.

DT has extremely low noise figure, the entire unit adopts twin-stage amplification, and the pre-amplifier adopts low noise EDFA, output cascade adopts high power EDFA. When input optical power  $P_{in}=0\text{dBm}$ , the noise figure of unit is  $\leq 5.5\text{dB}$  Unlike other kind of product which need high optical power input to maintain lower noise figure.

DT optical amplifier adopts the world's top class pump laser and active optical fiber. Perfect APC, ACC and ATC control, excellent design in the ventilation and heat-dissipation ensure the long life and high reliable work of pump laser. RS232 and RJ45 offer serial commutation and SNMP network management port.

DT LCD at the front panel offers the work index of all equipment and warning alarms. The laser will switch off automatically if optical power is missing, which offers security protection for the laser. All the optical port of optical amplifier can be installed in the front panel or back panel.

DT optional two-way optical input (built-in 2x1 optical switch), can be used for self-healing ring network or redundant backup network.

DT with carrier-class reliability and network security management, high quality, high reliability and excellent cost performance and is ideal for system integrators and system operator.

DT optical amplifier: 19" 2RU chassis, total output power up to 41dBm (13000mW), use LC/APC, offers 64 optical outputs at most, 64pcs uplink optical ports.

## **2.0 PRODUCT FEATURE**

- 1540~1563nm operating bandwidth for optical amplifier
- Each output optical port is with built-in high performance CWDM, single fiber three wavelengths, which can save optical fiber resources largely.
- Simplified machine-room links, improve the system reliability, and largely reduce the .network maintenance cost
- Can compatible with any FTTx PON technology: EPON/GEAPON, GPON
- Total output power optional 1260~13000mW ( 31~41dBm )
- 19" 2U rack up to optional 64 up-link ports, which used in OLT; And 64 1550nm output optical ports, multiplex the 1310/1490nm data stream.
- Built-in low noise pre-amplifier, not necessary EDFA cascade, extremely lower the CNR, MER degradation of the system
- Low noise figure  $\leq 5.5\text{dB}$
- Perfect RS232 ,SNMP
- Telecom level safety reliability and network management
- Efficient space, simple and reliable in construction/maintenance
- Optional dual optical input, built-in  $2 \times 1$  optical switch
- Dual power supply optional, 1+1 backup
- Can reduce the 98% device space usage
- Can reduce the 85% device purchase cost
- Can reduce 95% power consumption
- Industry's best price-performance

## **3.0 MAIN APPLICATION**

- FTTx PON
- RFoG

## 4.0 Technique index

Performance		Index			Supplement	
		Min.	Typ.	Max.		
Optical feature	CATV operation wavelength	(nm)	1540		1563	CATV
	OLT pass wavelength	(nm)		1310/1490		
	CATV pass wavelength loss	(dB)			0.8	1550nm
	OLT pass wavelength loss	(dB)			0.8	1310/1490nm
	CATV & OLT isolation	(dB)	40			
	Number of uplink optical ports (for OLT)	(pcs)			64	
	CATV input power (Pi)	(dBm)	-10		+10	
	Total output power <sup>1)</sup>	(dBm)			41	
	Number of output ports	(pcs)			64	
	Each port output power	(dBm)	0		22	
	Difference of each output power	(dB)	-0.5		+0.5	
	Output optical power monitoring	(dB)		-20		Optional
	Output power adjustable range	(dBm)	-6		0	Optional
	Noise figure	(dB)		4.5	5.5	DT □□□
				5.0	6.0	DT □□□
	Switch time	(ms)			8.0	DT □□□
	Polarization dependence loss	(dB)			0.3	
	Polarization dependence gain	(dB)			0.4	
	Polarization mode dispersion	(ps)			0.3	
	Input/output isolation	(dB)	30			
Pump power leakage	(dBm)			-30		
Echo loss	(dB)	55			APC	
General feature	Network management interface		RJ45		SNMP	
	Serial interface		RS232			
	Power supply	(V)	90		265	220VAC
30				72	-48VDC	

Power consume	(W)			84	
Operation temp.	(°C)	-5		65	
Storage temp.	(°C)	-40		80	
Relative humidity	(%)	5		95	
Size (W)×(D)×(H)	(")	19×14.7×3.5			DT (2U)

## 5.0 OPTIC/ELECTRICAL SCHEMA

### 5.1 DT □□□ (conventional)

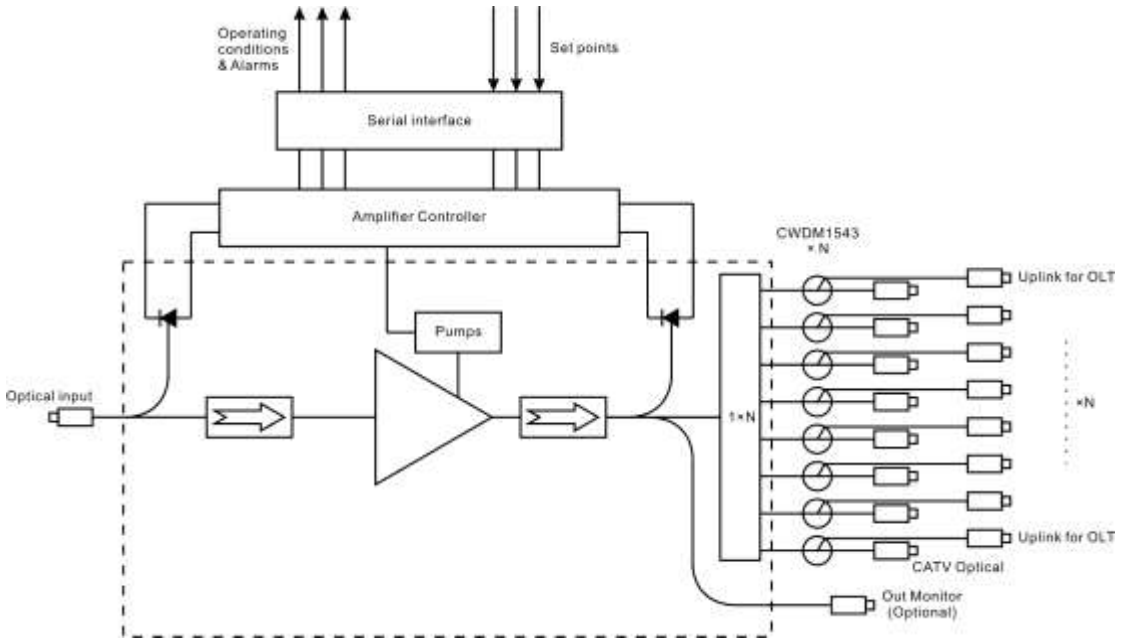

### 5.2 DT □□□ (Built-in Optical Switch)

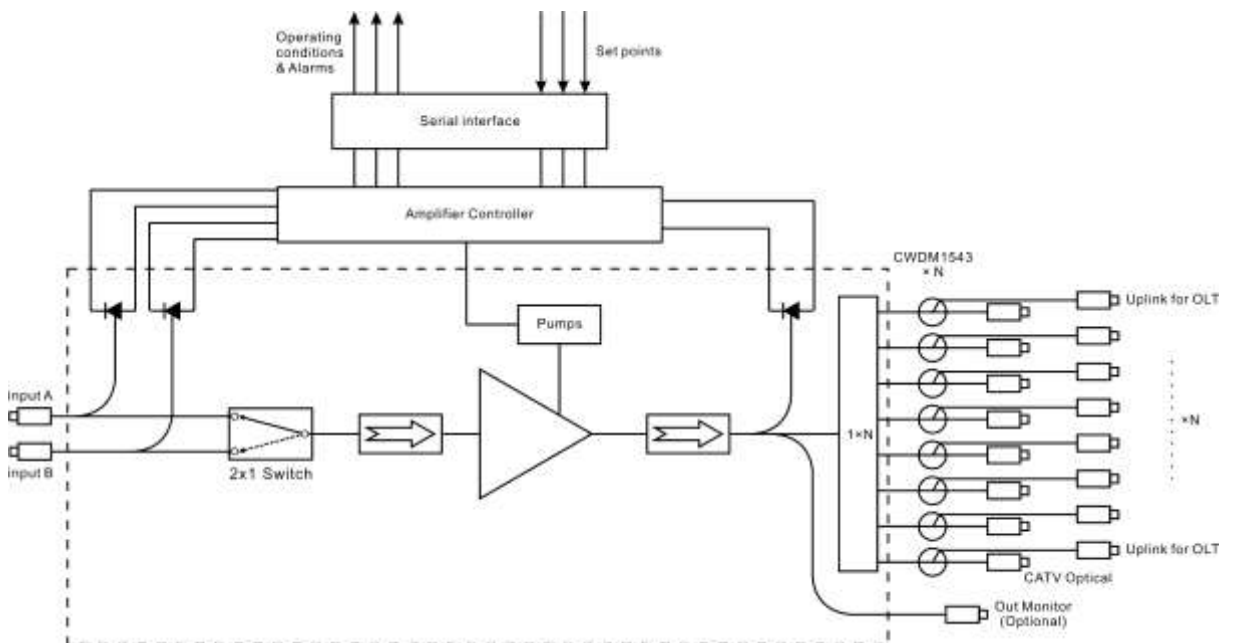

## 6.0 PRODUCT SERIES

Model number	Total output power	Number of output port	Each port output power	Connector
DT32*13B-32	31dBm (1260mW)	32	13.0	SC/APC、LC/APC
DT32*14B-32	32dBm (1600mW)	32	14.0	SC/APC、LC/APC
DT32*15B-32	33dBm (2000mW)	32	15.0	SC/APC、LC/APC
DT32*16B-32	34dBm (2500mW)	32	16.0	SC/APC、LC/APC
DT32*17B-32	35dBm (3200mW)	32	17.0	SC/APC、LC/APC
DT16*21.5B-16	36dBm (4000mW)	16	21.5	SC/APC、LC/APC
DT32*18B-32		32	18.0	SC/APC、LC/APC
DT32*19B-32	37dBm (5000mW)	32	19.0	SC/APC、LC/APC
DT64*15.5B-64		64	15.5	LC/APC
DT32*20B-32	38dBm (6300mW)	32	20.0	SC/APC、SC/UPC
DT64*16.5B-64		64	16.5	LC/APC
DT32*21B-32	39dBm(8000mW)	32	21.0	SC/APC、LC/APC
DT64*17.5B-64		64	17.5	LC/APC
DT32*22B-32	40dBm(10000mW)	32	22.0	SC/APC、LC/APC
DT64*18.5B-64		64	18.5	LC/APC
DT32*23B-32	41dBm(13000mW)	32	23	SC/APC、LC/APC
DT64*19.5B-64		64	19.5	LC/APC